

## SRC-200 Series Climate Controllers with BACnet MS/TP

The SRC-200 series controllers have been designed for climate control in room spaces. The controllers have up to two heating and cooling temperature control stages, fan speed control, optional CO2 level and humidity control. The units can be in various climate control applications including VAV, fan coil units and natural ventilation systems. The controllers have 4 analogue 0..10Vdc outputs and two digital outputs that can be configured for heating, cooling, CO2, humidity, maximum VAV demand or maximum fan demand control. The controllers can operate as Proportional Only or as Proportional + Integral Controllers.

The analogue outputs can be individually configured for any of the heating/cooling stages, CO2, maximum VAV demand or Humidity control. The digital outputs can be configured as 3-point, PWM (thermic) or On/Off control. The SRC-200CO2 versions have built-in CO2 measurement and the outputs can be controlled based on CO2, maximum VAV demand (temperature and CO2), or maximum Fan demand. The SRC-200RH versions humidity measurement and can be used to increase ventilation when high humidity is present.



The controller setpoint can be adjusted  $\pm 3^{\circ}\text{C}$  (default) by rotating the potentiometer. In the display models, the display shows comprehensive information on the controller status. With AI options it is possible to monitor/control 0-10V inputs.

The controllers have built-in BACnet MS/TP communication for connection to BMS systems but can also operate as stand-alone..

Model Type	Model	Description
	<b>SRC200-BAC</b>	Space Climate Controller with Heating and Cooling Outputs, Fan Speed Control, LCD Display, BACnet MS/TP
	<b>SRC200-CO2-BAC</b>	Space Climate Controller with Heating and Cooling Outputs, CO2 Sensor and Control, Fan Speed Control, LCD Display, BACnet MS/TP
	<b>SRC200-RH-BAC</b>	Space Climate Controller with Heating and Cooling Outputs, Relative Humidity Sensor and Control, Fan Speed Control, LCD Display, BACnet MS/TP
	<b>SRC200-CO2RH-BAC</b>	Space Climate Controller with Heating and Cooling Outputs, CO2 Sensor and Control, Relative Humidity Sensor and Control, Fan Speed Control, LCD Display, BACnet MS/TP
	<b>-PB</b>	Push Button Option
	<b>-SPB</b>	Push Button Setpoint Option (Replaces Rotary Potentiometer Setpoint)
	<b>-LL</b>	Light Level and Occupancy Sensor (only available when Rotary Setpoint is not fitted) <sup>Note1</sup>
	<b>-TP</b>	No User Setpoint Adjustment (no potentiometer or push button setpoint provided)
	<b>-BL</b>	No Display or User Setpoint Adjustment (Potentiometer or Buttons) fitted, Blank Cover or Cover with Light Sensor
	<b>-RI2</b>	Extra Resistive Input for Network Measurement Only (device supplied with -SPB option for temp setpoint, no pot)
	<b>-AI1</b>	Converts RI1 to Analogue 0..10Vdc input, network measurement and/or PI-control <sup>Note2</sup>
	<b>-AI2</b>	Second analogue input for Network Measurement (device supplied with -SPB option for temp setpoint, no pot) <sup>Note3</sup>
	<b>SW-DCT-USB</b>	Windows Device Configuration Tool with 1.8m USB Cable
	<b>-TP</b>	No User Setpoint Adjustment (no potentiometer or push button setpoint provided)

**Note 1: The LL option disables the external resistive input 1.**  
**Note 2: If AI1 option is selected, RI2 (second resistive input) option is no longer available**  
**Note 3: AI2 option requires AI1 option (it is not possible to have a mix of resistive and analogue inputs)**

**Technical Data**

Power Supply	Power supply	24Vac/dc -10%/+15% <1VA
Displays and Interfaces	LCD	LCD Display for Showing Plant Status (Heating/Cooling Mode, Current Temperature, CO <sub>2</sub> , Humidity, Setpoint, Valve Position, Fan Speed, Day/Night Mode, Amber/Red Alarms)
	Setpoint Potentiometer	Setpoint Adjust between 18°C and 24°C (limits adjustable)
	Option -PB	Backlit Multi-Step Push Button with Delay Timer; Can be configured Override the Control Loop Outputs
	Option -SPB	Setpoint with 2 Push Buttons (adjustable min/max limits) <i>ote: If this option is selected PB option becomes 3rd button.</i>
Signal Outputs	Analogue Outputs	4 x 0..10V < 5mA
	Digital Outputs	2 x 24Vac Triacs; 1A maximum; requires 24Vac Power Supply
Signal Inputs	Built-In Sensor	0..50°C (32..122°F) ±0.3°C @ 25°C
	Resistive Input 1	1 x External NTC10K3 Sensor (Auto-Detect)
	Resistive Input 2 (RI2 Option)	1 x External NTC10K3 Sensor (device supplied with push button setpoint -SPB instead of the setpoint pot)
	Analogue Input (AI1 Option)	1 x 0..10Vdc (replaces the resistive input 1)
	Analogue Input (AI2 Option)	1 x 0..10Vdc (replaces setpoint pot, the device supplied with -SPB push button setpoint)
	Digital Input	2 x Digital Input, Volt-Free Contact, Impedance <1KOhm
Optional Sensing	Carbon Dioxide (CO <sub>2</sub> Models)	
Characteristics	Range	0..5000ppm CO <sub>2</sub>
	Accuracy	± 50ppm + 3% of the reading @ 25°C (@77°F)
	Technology	Auto Calibrating; Patented Non-Dispersive Infrared (NDIR)
	Non-Linearity	<1% FS
	Warm-Up Time	<20 seconds
	Response Time	2 minutes
	Humidity (RH Models)	
	Range	0..100%rH
	Accuracy	±2% rH (within 20..80% rh)
	Light Level and Occupancy; Option -LL	<i>Note: If this option is selected RI1 (resistive input) is no longer available and need to be left disconnected - this will also disable the sensor auto-detection.</i>
Range	0..3,000 Lux	
Occupancy	Infrared Detection (Adjustable Delay)	
Communication	BACnet Communications	
	Protocol	BACnet MS/TP
	Interface	RS485; maximum 63 devices
	MAC Addressing	0..63 via a bit switch; 0..247 via tool / network
Communication	9k6/19k2/38k4/76k8 Baud; Parity None/Even/Odd, 1 or 2 Stop Bits (baud rate adjustable through bit switch)	
Connections	Terminal Connections	Solid and Stranded Cable; 55° Angle for Wiring Maximum Size: 0.05 to 1.5mm <sup>2</sup> (EN ISO) / 14 to 30 AWG (UL) Rising Clamp: Size 2.5 x 1.9mm
Environmental Conditions	Operating	
	Temperature	0°C...+50°C (32..122°F)
	Humidity	0..95%rh (non-cond.)
	Storage	
Temperature	-30°C...+70°C (-22..158°F)	
Humidity	0..95%rh (non-cond.)	
Standards	CE Conformity	CE Directive 2004/108/EY EN61000-6-3: 2001 (Generic Emission) EN61000-6-1: 2001 (Generic Immunity).
	Degree of Protection	IP20

Housing	Housing Material	ABS Plastics, Self Extinguishing
	Mounting	Wall or Junction Box Mounting, RAL9010 Pure White
	Dimensions	W86 x H120 x D29mm
	Weight	220g

**Wiring Connections**

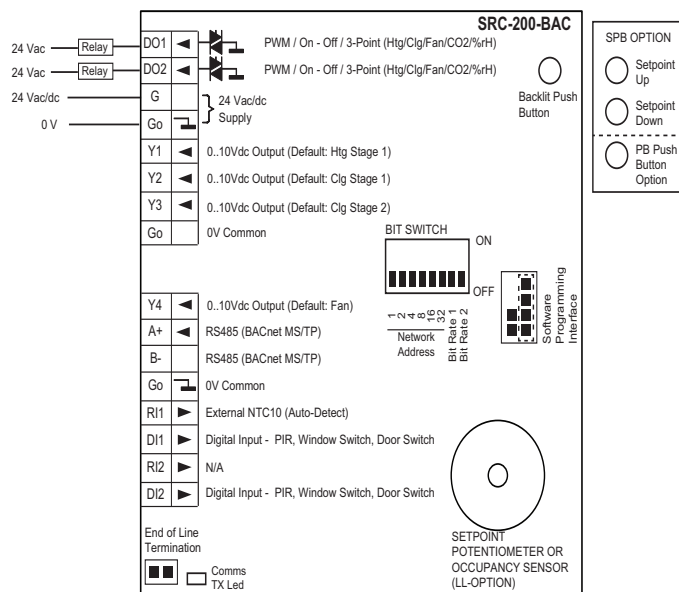

DO1	24Vac Triac; PWM, On/Off; 3-Point Open
DO2	24Vac Triac; PWM, On/Off; 3-Point Close
G	24Vac/dc Power Supply
Go	0V Common
Y1	0..10Vdc Output
Y2	0..10Vdc Output
Y3	0..10Vdc Output
Go	0V Common
Y4	0..10Vdc Output
A+	BACnet MS/TP A+ Connection (RS485)
B-	BACnet MS/TP B- Connection (RS485)
Go	0V Common
RI1	External NTC10 Sensor (Auto-detect for main loop)
DI1	Digital Input; PIR Input, Windows/Condensation Switch
RI2	Not Applicable
DI2	Digital Input; PIR Input, Windows/Condensation Switch

**Wiring Precautions**

Switch off the power before any wiring is carried out.

Display: Unplug the LCD display and then wire the power supply and the analogue outputs, if relevant. After the wiring has been completed; plug-in the display and power up the device.

**Application Examples**

The below application diagrams show few examples of the SRC200 Climate Controller applications. The controller is highly versatile and can be easily configured for most room heating and cooling applications including fan coil unit control, chilled ceiling and zone heating, VAV pressure dependent control and natural ventilation. Please refer to individual set up pages for further details or contact SyxtSense Sales Team for advice.

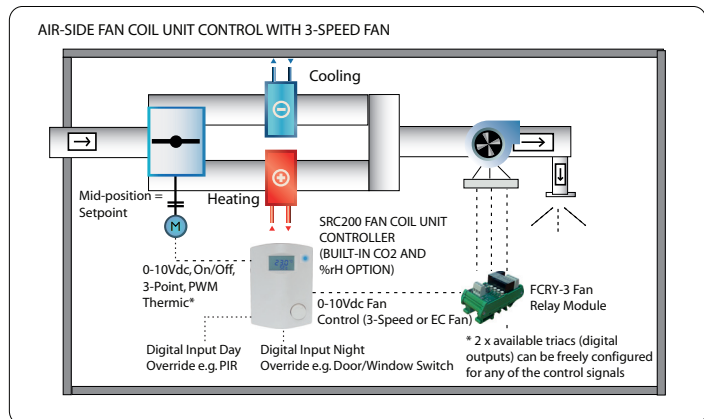
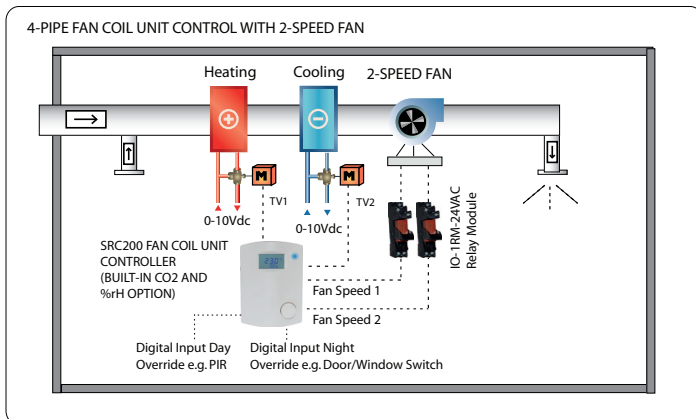
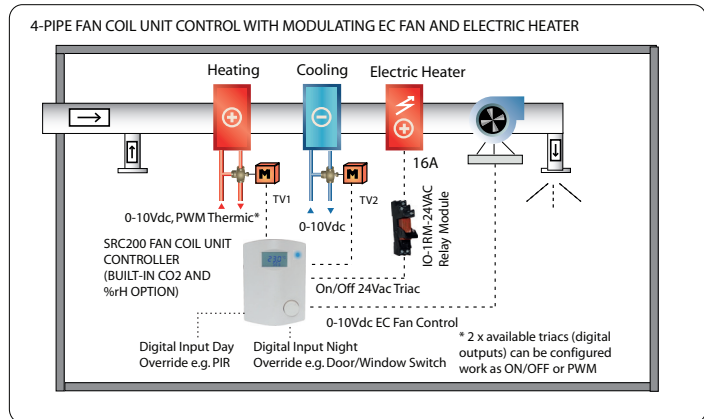
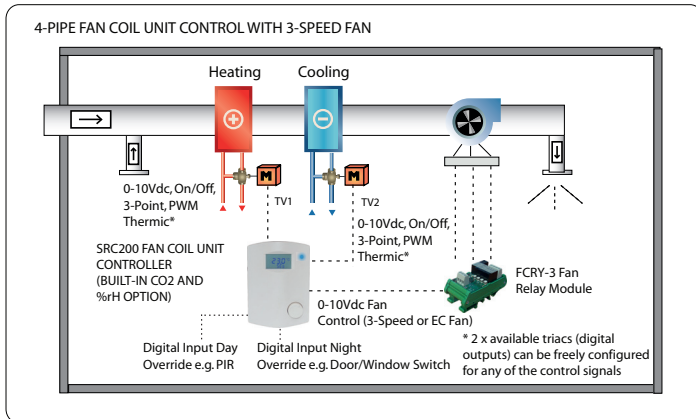
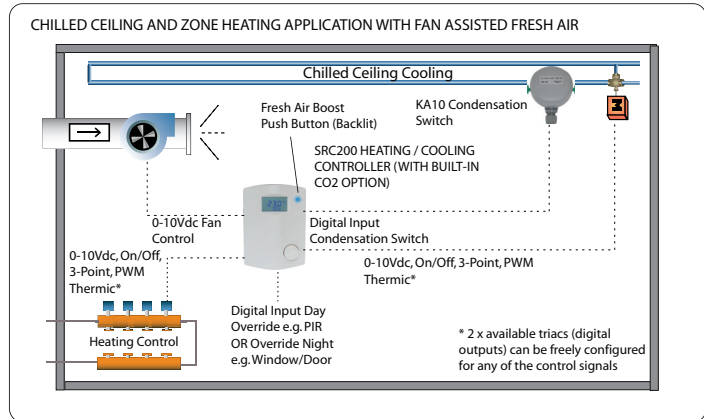
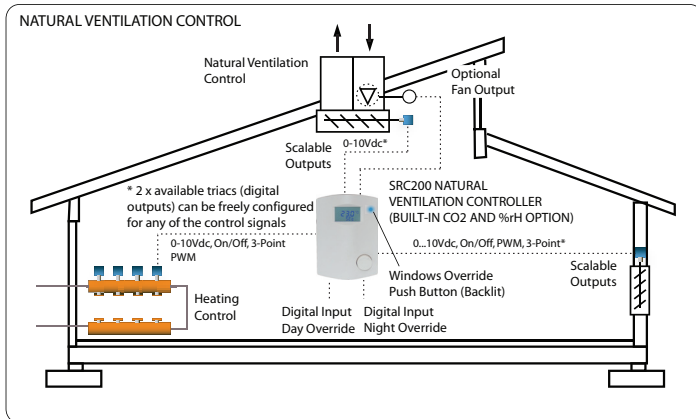

**Setpoint Adjustment**

By rotating the setpoint knob option it is possible to adjust the current temperature control setpoint +/-3°C. The adjustment shifts temperature setpoint up and down. Via the configuration tool it is possible to adjust the setpoint centre, and the min and max adjustments of the setpoint.

When the potentiometer is rotated the current setpoint is displayed on the screen (in display model), and the backlight is switched on momentarily.

The SPB option provides two push buttons for setpoint instead of the potentiometer. The adjustment shifts the temperature setpoint up or down up to the minimum and maximum allowable setpoint. A configurable parameter (Setpoint Adjust Reset) is available to automatically either reset or retain the current user setpoint adjustment when the setpoint is changed over the network. Furthermore Setpoint Adjust Save parameter is available to enabling saving the user setpoint adjustment to

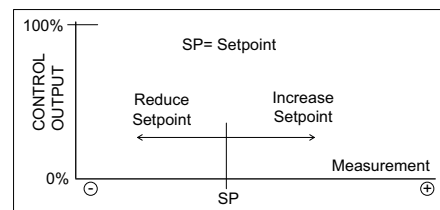

non-volatile memory. If this is enabled, after the power-cycle the controller returns to use the latest user adjusted setpoint.

**SRC200 User Interface**

The SRC200 controllers have a built-in backlit LCD that can be used to show the current status of the controller. The display is also used to show number of configuration settings. The images below illustrate different display options.

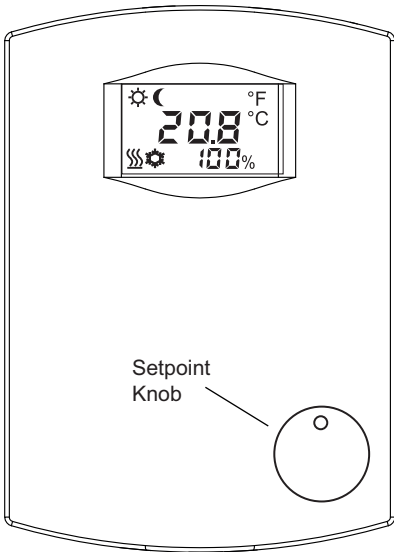

**Display Icons**

- ☀ Heating Mode
- ⚙ Cooling Mode
- °C °F Temperature Reading
- 100% Current Valve Position
- 58.7%RH Relative Humidity
- ⚙ Day Control
- ☾ Night Control
- ⚙ 3-Speed Control
- ⚙ 82% Modulating Fan Speed

**USER DISPLAY MODES**

TEMPERATURE DISPLAY WITH VALVE POSITION, HEATING, NIGHT

SETPOINT DISPLAY ADJUSTMENT (+/-3°C OF SP CENTER)

SETPOINT ADJ IS SHOWN WHEN KNOB IS ROTATED

TEMPERATURE DISPLAY (FAHRENHEIT) 3-SPEED FAN SPEED DISPLAY DAY MODE ICON HEATING ICON

ANIMATING FAN FAN SPEED OPTIONS MODULATING FAN SPEED

**ALARM DISPLAY EXAMPLES**

TEMPERATURE AMBER ALARM FLASHING °C

CO2 RED ALARM FLASHING PPM

FLASHING WHEN COOLING OVERRIDE VIA PUSH BUTTON

ALTERNATING CO2 MEASUREMENT AND HUMIDITY MEASUREMENT (POSSIBILITY TO SELECT ALTERNATING DISPLAY, OR TEMP AND VALVE POS ONLY)

**LCD Display**

The LCD display shows the controller current operation status to the user.

- Temperature, CO2 Level, Humidity Measurement (CO2 model; can be configured to auto-rotate between CO2 and temperature. RH model; configured to auto-rotate between valve/fan position and humidity measurement)
- Current Cooling/Heating Demand with heating and cooling mode icons (Set Info Line to Show the Valve Output)
- No heating or cooling icon if neither heating or cooling stages are active. Note: With PI control the outputs are usually active within the deadzone.
- Day Mode / Night Mode icon
- Fan Speed (modulating or A-0-1-2-3; set the Info Line to show Fan Speed)
- CO2, Temperature, Humidity Alarm Display (amber/red)

The display can show either the Fan Speed or Valve position. This is configured during the commissioning. If CO2 is fitted, the CO2 reading can be configured to be rotated with the temperature reading. If RH is fitted, the %rH reading can be configured to be rotated with the fan speed/valve position

**External Sensor Input (RI1 Input)**

The controller uses as default the internal temperature sensor for the main temperature control loop. If an external NTC10 temperature sensor is connected to the input RI1, and a valid sensor reading is measured, the controller starts automatically to use the external temperature sensor for the main control loop.

If the Aux Temperature Control Loop has been enabled the RI1 external temperature sensor is used for Aux Control Loop and is no longer available for the main temperature control loop.

**External Sensor Input 2 (RI2 Input)**

With option RI2 it is possible to provide extra measurement for the external NTC10 sensor. The measurement is available over the communication network.

If the RI2 option is selected, the controller is supplied with -SPB push button setpoint instead of the setpoint potentiometer knob.

**0-10V Inputs (AI1 & AI2)**

With AI1 option the external sensor input is converted to operate as 0-10V input. The 0-10V input can be used either for network monitoring, or by enabling the Auxiliary Control Loop, the 0-10V measurement signal can be used in the auxiliary PI control loop.

If AI1 option is selected, then with AI2 option it is also possible to have second 0-10V input for measurement only over the communication network. In this case the controller will be supplied with -SPB push button setpoint for the temperature control loop (setpoint knob is no longer available).

**NOTE:** With AI-options it is no longer possible to have any external resistive NTC10 sensor inputs.

**Temperature Control Loop Operation**

The controllers can have up to 2 heating stages and up to 2 cooling stages (as default one heating stage and one cooling stage) for temperature control. The controller modulates the heating and cooling demand outputs according to the calculated setpoint and the current internal (or external) temperature. The control can be either P-control or PI-control.

As default, heating stage 1 output is linked to Y1 for fully modulating 0..10Vdc control, cooling stage 1 is linked to analogue output Y2 and cooling stage 2 to analogue output Y3.

The controller has also two digital outputs that can be configured to work as PWM or 3-Point control. The PWM or 3-Point control can then be linked to any of the control stages (Heating Stage 1/2 or Cooling Stage 1/2) as required. As default DO1 is linked to PWM control of heating stage 1 and DO2 is linked to the PWM control of cooling stage 1.

Please note that it is possible to set the control loop outputs to direct/reverse, which reverses the control output (valve) running direction (valve drives from 100% to 0%). This can be configured individually for each stage in the Configuration Tool.

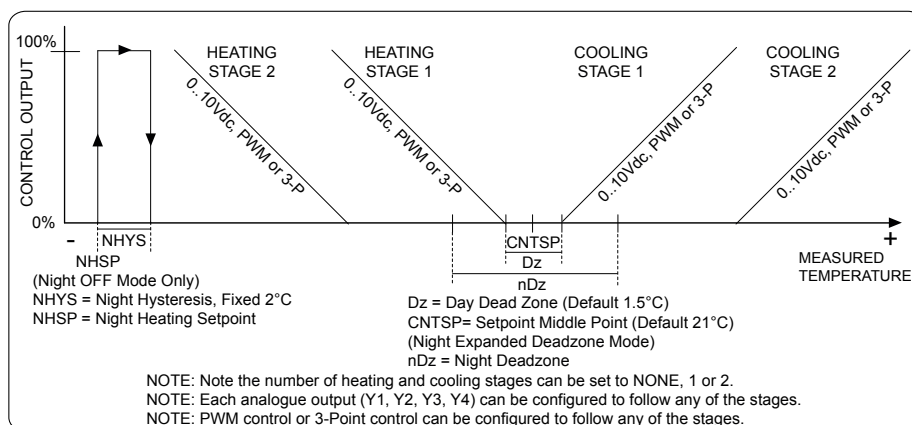

Between heating and cooling stage 1 is a control deadband. This prevent rapid switching between heating and cooling.

**Day and Night Control**

The controller has Day and Night operation modes. When in Day mode the control loop operates with the (Day) Deadzone value. In the Night time the controller controls with the Night Deadzone, if the night mode has been configured to operate in the Expanded Deadzone mode. If in Night Off mode has been enabled the outputs are Off unless the temperature drops below the Frost Setpoint (8°C, adjustable). In this case the Heating Loop Stage 1 and 2 outputs are 100% until the temperature reaches Frost Setpoint + 2°C.

In the Night Mode the LCD display shows the Night Icon (half moon icon). In the day mode the Day Icon is displayed (sun icon).

The day/night control selection can be controlled via the network, via digital inputs or via the optional occupancy sensor.

**Night/Day Control Activation (Digital Input 1 and 2, or LL-Option)**

The controller can be switched to operate between DAY MODE / NIGHT MODE via the communication bus or via the digital inputs (volt-free contact), or via built-in Occupancy Sensor (-LL Option).

The Digital Inputs has multiple modes; PIR MODE (override to Day), WINDOW SWITCH MODE (override to Night), CONDENSATION SWITCH MODE (disable cooling).

- In the PIR MODE the controller DAY MODE is activated when the digital input is closed. If the digital input opens, the controller returns to NIGHT MODE (automatic control) after an adjustable time delay
- In the WINDOW SWITCH MODE the controller goes to NIGHT MODE if the digital is open. If the digital input closes, the controller returns to DAY MODE (automatic control) after an adjustable time delay. This can be, for example, used for window contacts or door cards.
- In the CONDENSATION SWITCH MODE, the cooling stages are disabled when the digital input closes.

The built-in Occupancy Sensor (LL-option) operates like the PIR MODE above.

Local overrides have priority over the communication network. Condensation switch mode has priority over the PIR mode. The PIR mode has priority over the window switch mode.

**Fan Speed Control**

Fan speed control logic adjusts the fan speed based on the demand (as default heating stage 1, cooling stage 1 control loop outputs). The fan speed control can operate in 1-speed, 2-speed, 3-speed, or EC fan control modes.

The fan speed control type (EC fan, 0-1, 0-1-2, 0-1-2-3) is configured in the Configuration Parameters.

The fan is as default controlled based on the heating stage 1 and cooling stage 1. It is possible to change the fan control source to follow also only the heating stage 1, or only the cooling stage 1, heating/cooling stage 2, heating stage 2, cooling stage 2, humidification, de-humidification, CO2 loop or Aux temperature control loop.

Note: In the Expanded Night Deadzone mode the fan speed is also controlled based on the Heating Stage 1 and/or Cooling Stage 1 demand. In the Night Off mode, the fan speed is controlled based on the Frost Stage demand.

Note: Using external fan control modules such as FCRY-3, it is possible to drive 3-speed fan motors directly. In this case connect analogue output, set to MODULATING FAN, to the FCRY-3 module.

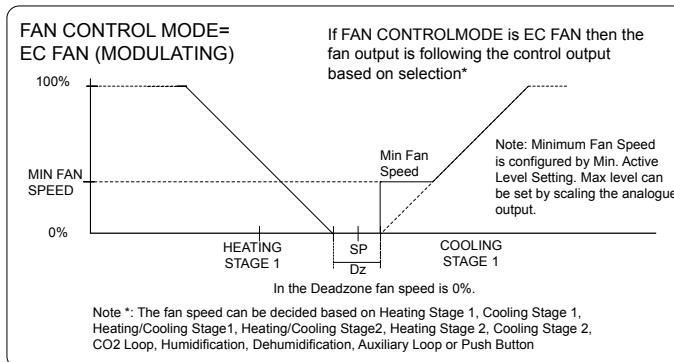
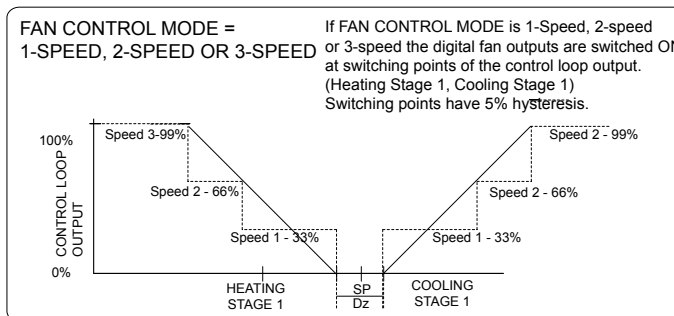

EC Fan Control

When controlling the fan it is possible to set the minimum fan speed level. The fan speed will not drop below the min level in the selected fan control active stage(s) (heating1, cooling2 etc.). When in the deadzone or in other control stages the fan speed drops to 0%.

If the EC Fan is required to be running at the Deadzone, please use the Output Limitation/Scaling.

**Air-Side Control Logic**

Air-side control is implemented by combining the Heating Stage1 and Cooling Stage 1 demands. As such to use air-side the number of heating stages must be set to 1 or more and the number of cooling

stages must be set to 1 or more. In normal operation the stage direction for heating stage 1 and cooling stage 1 should be set the same.

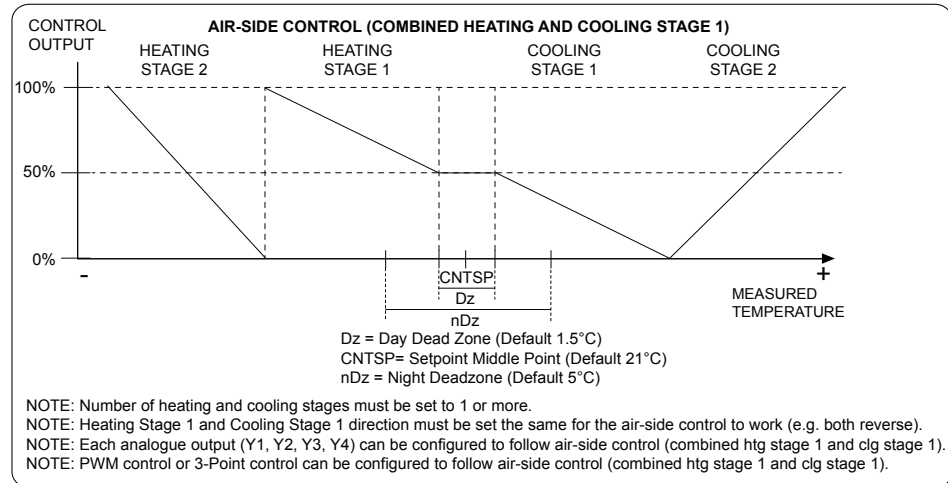

**Note:** The effective proportional band of the Air-side control is twice that of the Heating2 and Cooling2 stages due to the fact there is only one proportional band setting for all stages.

**CO2 Sensor Control Loop Operation (SRC200-CO2 Models)**

The CO2 models can measure and control the CO2 level. This can then be used in demand based control applications. The CO2 control output can then be configured to linked to any of the physical control outputs Y1, Y2, Y3 or Y4.

The CO2 control loop output corresponds to the CO2 setpoint and the CO2 proportional band. If configured as Direct Control (typical), then if the CO2 level increases above the setpoint the loop output starts to modulate to 100%. When the CO2 level is the amount of the Proportional Band above the setpoint, the loop output is 100%. The configuration is done via the configuration parameters. The CO2 control loop can also be configured to operate as Proportional + Integral control by changing the Integral Action Time from 0 to a required value.

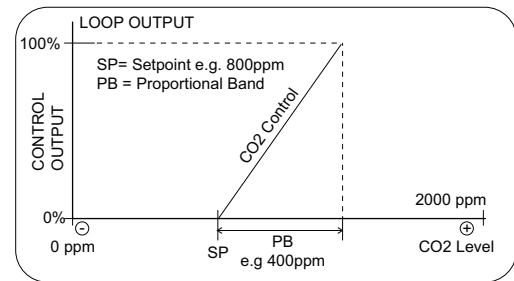

**NOTE:** CO2 measurement is enabled by inserting CO2 link jumpers (two) on the programming header. As default these are fitted (See programming interface section for further details).

**Auxiliary Control Loop**

The SRC controllers have auxiliary (temperature) control loop option. When activated, the auxiliary loop uses the RI1 NTC10 temperature reading to calculate the required control output.

The auxiliary loop can be configure to operate direct or reverse.

Note: If auxiliary loop is not activated, the RI1 is used for the main temperature control loop automatically (auto-detect).

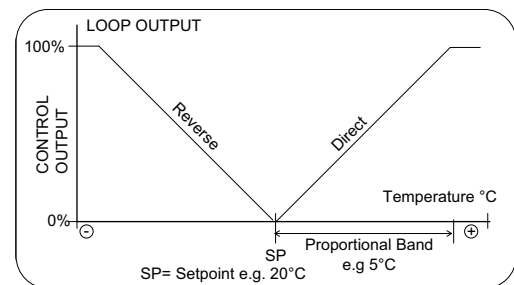

When AI1 option is fitted and the auxiliary control loop is enabled, the control loop can be used for 0-10V control. The setpoint and proportional band corresponds to the 0-100% input range. This can be used e.g. in pressure control.

**CO2 Measurement Auto-Calibration**

The CO2 sensor has automatic auto-calibration feature. This feature monitors the background CO2 level over the calibration period (8 days), and calibrates the CO2 level to the lowest point measured during this period. The sensors are supplied as factory calibrated to the typical background levels. After powering up the sensor, the sensor carries out initial calibration within 1 day after which the CO2 level is calibrated every 8 days automatically. The auto calibration logic virtually eliminates the need for manual calibration in applications where the indoor CO2 drops to outside levels during unoccupied periods.

**NOTE:** If the CO2 sensor is fitted in spaces where the background level does not drop close to the typical background level (= fresh air) of 400ppm (e.g. greenhouses) it is essential that the auto-calibration feature is disabled during the commissioning.

**VAV Maximum Demand Application**

Each of the analogue outputs can also be configured as "Maximum VAV Demand". In this case the corresponding output (Y1, Y2, Y3, Y4) takes the maximum of the CO2 Loop and Cooling Temperature Loop demand output. This is typically used in demand based ventilation (VAV) to control fresh air



damper when there is either demand for more fresh air, or demand for temperature cooling (typically fresh air cools down the room space).

#### Maximum Fan Demand

Each of the analogue outputs can be configured as "Maximum Fan Demand". In this configuration the corresponding output (Y1, Y2, Y3, Y4) takes the maximum demand of the CO2 Control Loop and Fan Speed Control Loop. This can provide fan speed boost at high CO2 level and when the fan speed temperature loop has increased the demand.

#### Humidity Control Loop Operation (SRC-200RH)

The RH models can measure and control the relative humidity level. This can then be used in demand based control applications to increase the fresh air supply e.g. in the high humidity conditions. The control loop has both de-humidification and humidification outputs that can be linked to any of the physical control outputs Y1, Y2, Y3 or Y4. The direction of the both outputs can also be reversed to driver the actuators 100-0% instead of 0-100%.

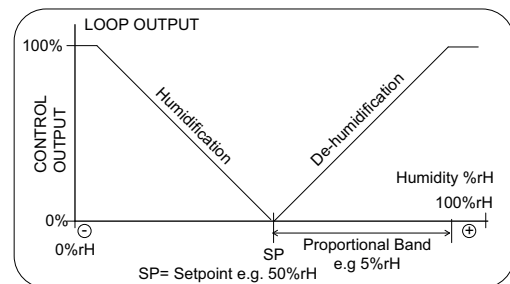

#### Output Scaling / Output Limitation

Each of the analogue outputs (Y1, Y2, Y3, Y4) can have

- Output minimum voltage (percentage)
- Output maximum voltage (percentage)

The connected control loop output 0..100% is then scaled from minimum voltage to maximum voltage.

For example in the EC fan control, if the fan is required to run always at minimum level, the minimum control output voltage can set to 10% (1V) and the maximum output 70% (7V). In this case the output is 1V when the control loop output is less than 10% and the output is 7V when the control loop output is more than 70%. This allows maximum noise levels to be limited and the fan to have a minimum fan speed. In this example the fan is running at 10% within the deadzone. If the fan is required to be off in the deadzone, please use the Min Active Level in the Fan Speed Control section.

The values are available via the communication network from network master read/write. This allows them to be used e.g. in the natural ventilation application limit the window damper position to different values in winter and summer.

#### Digital Output Triac Operating Modes, (Thermic Control, 3-Point Control, On/Off Control, Fan Control)

The digital outputs (24Vac Triacs that switch 24Vac to 0V) can be configured to operate as 3-point control, as PWM control (pulse width modulation control) or as On/Off control. They can also be configured as outputs to fan speed control (when 1-speed or 2-speed mode selected). The type of the control is selected via the configuration parameters. If the 3-point actuator mode is selected, the controller modulates the DO1 on when valve is required to be opened and DO2 when the valve is required to be closed. The 3-point operation can be configured to follow any of the heating/cooling stages, CO2 control loop, humidity control loops, air-side control or Maximum VAV/FAN.

It is also possible to reverse the output operation by reversing the corresponding loop output.

When the 3-point output is driven fully open or closed, the output is driven against the edge for a "run on" period (default 6 seconds) and this will be repeated every 10 minutes. The run on time time adjustable via the configuration parameters and this behaviour can be disabled completely by setting the run on time to 0.

If PWM actuator is used the duty cycle is 30 seconds as default (configurable via the tool). E.g. if the output is at 50% then the output is ON for 15 seconds and OFF for 15 seconds.

If the PWM mode has been set to On/Off, then the corresponding digital output is switched ON at the Max Level (default 100%) and are switched OFF at the Min level (default 0%).

Note: Please note digital outputs switch to 0V (24Vac is switched to 0V through the triac).

By setting the Analogue Output Y1, Y2, Y3, Y4 to 3-Point Open or 3-Point Close, the analogue output emulates the digital output. If the 3-point logic drives open, and if the analogue output is set to 3-Point Open, the analogue output is set 10V when opening, otherwise 0V. If the 3-point logic drives close, and if the analogue output is set to 3-Point Close, the analogue output is set 10V when closing, otherwise 0V. This can be used with natural ventilation wiring center to drive window actuators.

The 3-point actuator can have two modes, Linear and Stepped. In Linear Mode the 3-point output operates as standard 3-point control. In Stepped Mode the 3-point loop output will not change until the demand has exceeded the configured step amount. This allows the 3-point loop output to be configured to provide e.g. only output values of 0-25-50-75-100%. This reduces the wear and tear on the Windows actuators. The number of steps is defined by the "Push Button Steps" parameter.

#### CO2, Humidity, Temperature, Fan and Direct Output Override via Push Button (-PB Option)

Pressing the Push Button, the CO2, Humidity, Fan Speed, Temperature Control Loop Stages or physical Outputs (Y1/Y2/Y3/Y4) can be overridden to 100%, to 0% or to a user adjusted value (Stepped Mode; e.g. 0-25-50-75-100%) for time specified in the override delay parameter. Push Button Operation parameter defines the push button mode (0%, 100% or Stepped). When the override is active, the button backlight in ON.

In case of Open (100%) or Close (0%) Modes, the override can be cancelled by pressing the push button again. In this case the controller returns to normal automatic operation.

In case of Stepped mode, the output is rotated between Cancel and Stepped positions (see below table). Rotating to the Cancel, cancels the override and the controller returns to normal operation.

The possible "Push Button Steps" Configuration Options:

Push Button Steps	Description
1	Cancel - 0% - 100%
2	Cancel - 0% - 50% - 100%
3	Cancel - 0% - 33% - 66% - 100%
4	Cancel - 0% - 25% - 50% - 75% - 100%
5	Cancel - 0% - 20% - 40% - 60% - 80% - 100%

The Push Button Boost target defines which control loop the push button overrides.

Push Button Target	Description
Heating Stage 1	Overrides the Heating Stage 1
Heating Stage 1&2	Overrides the Heating Stage 1&2
Cooling Stage 1	Overrides the Cooling Stage 1
Cooling Stage 1&2	Overrides the Cooling Stage 1&2
Fan Speed Control	Overrides the Fan Speed
CO2 Control Demand	Overrides the CO2 Control
Humidification Demand	Overrides the Humidity Control
De-Humidification Demand	Overrides the Dehumidifying Control
Maximum VAV	Overrides the Maximum VAV Output (Combined Temperature & CO2 Loop)
Output	When Push Button Override is Set to None, the individual outputs can be overridden directly using the push button (Y1,Y2,Y3,Y4,Thermic1,Thermic2,3-Point)

**NOTE:** If the PB (Push Button) option is selected together with SPB option, the push button is the third button down on the controller. As default the push button does not have any printing on it, but on request e.g. fan icon can be printed on it.

**Occupancy Sensor (-LL Option)**

The LL option offers a low power Passive Infrared Motion sensor with 21mm Fresnel lens designed for HVAC ventilation and lighting control applications. The sensor detects human body within its detection range. The LL sensor employs a dual element pyroelectric infrared sensor with advanced electronics circuitry.

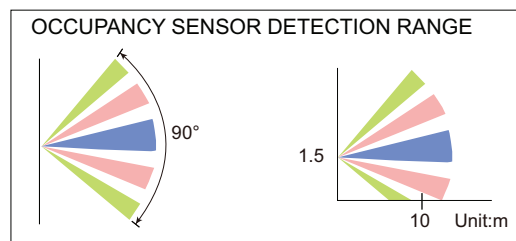

The occupancy sensor can be used for:-

- monitoring only (via network)
- switching the controller to day mode transition (PIR MODE - see DAY/NIGHT CONTROL ACTIVATION section)
- boosting heating stage 1 or cooling stage 1 to 100%
- boosting fan control loop or CO2 control loop to 100%

**Digital Input Operation**

The controller has two digital inputs that can be used for:-

- Override Day (see DAY/NIGHT CONTROL ACTIVATION section)
- Override Night (see DAY/NIGHT CONTROL ACTIVATION section)
- Disable Cooling Stages when Active
- None (Network Monitoring Only)
- Boosting heating stage 1 or cooling stage 1 to 100% (e.g. using external thermostat)
- Boosting fan control loop or CO2 control loop to 100%

**Alarm Display**

The SRC200 controller provides three Alarm modules each of which can be configured to detect and display Alarm condition on either the CO2, Humidity or Temperature Sensor (internal or external depending on which is being used). The alarm function can be disabled by setting the alarm source as "NONE". Alarms are disabled by default.

Each Alarm has three alarm states – No Alarm (White/No Backlight), Amber and Red.

HIGH LIMIT ALARM

If the Red threshold is set higher than the amber threshold:

If Sensor >=Amber Threshold; Alarm = amber

If Sensor >= Red Threshold; Alarm = Red

Hysteresis acts to prevent a return to a lower alarm level until the Sensor value falls to a Threshold - Hysteresis

**LOW LIMIT ALARM**

If the Amber threshold is set higher than the Red Threshold then:

If Sensor <= Amber Threshold; = amber

If Sensor <= Red Threshold; Alarm = Red

Hysteresis acts to prevent a return to a lower alarm level until the Sensor value rises to a Threshold + Hysteresis.

If one or more alarms are in a RED state then the RED backlight is turned on and the associated unit icons will flash on the display to indicate which sensor is causing the alarm(s).

If no red alarms exist Amber Alarms are processed instead and if any exist the AMBER backlight is turned on the associated sensor units flashed.

Note: The unit icons are only flashed when the associated sensor value is being displayed. So to display humidity and/or CO2 alarm, the display has to be configured to show also these.

If the AntiJAM function is enabled the controller monitors for inactivity. If the control outputs have been fully closed or fully open more than the AntiJAM period, the controller will open/close the outputs to by 30% (or ON/OFF in case of ON-OFF mode) for a short period of time. The AntiJAM function is enabled through the configuration parameters or via the DCT configuration tool by selecting the required AntiJAM period by days.

**ALARM DISPLAY EXAMPLES**

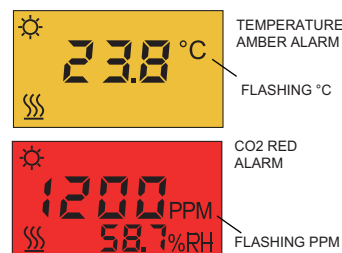

**AntiJAM Valve Exercise Function**

**Controller Configuration via Software Configuration Tool**

The controller parameter options can be configured either via the Device Configuration Tool software or via the Modbus parameters. The DCT tool is connected via the PC USB cable to the programming header of the controller as shown on the image below.

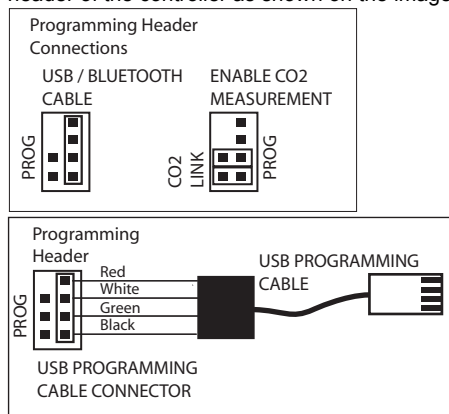

The correct process for connecting the controller via the USB is as follows:-

- Disconnect USB Connector from PC
- Disconnect the Controller from Power
- Plug-In the 4-Way Connector to the Sensor
- Connect the USB to the PC
- Power Up the Controller

**NOTE: Always disconnect USB from PC before plugging the cable into the controller.**

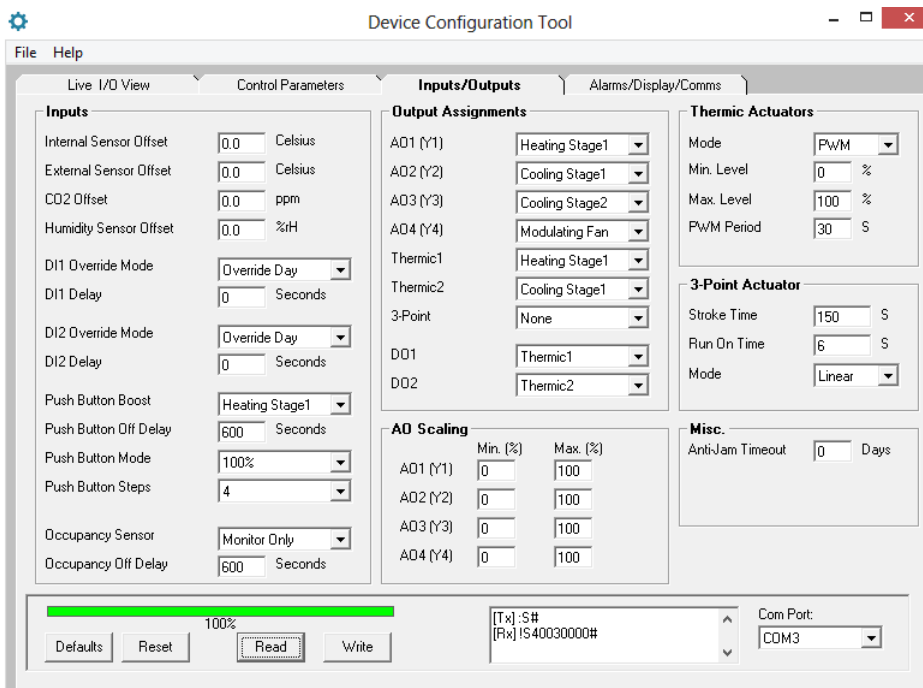

Common Parameters	
Parameter Name	Description
Defaults	Reloads the default configuration from the sensor non-volatile memory. <b>Note: All modified settings are lost.</b>
Reset	Performs soft reset of the controller. Apply after major changes.
Read	Reads the controller data.
Write	Writes the new settings to the controller (automatically stored in the non-volatile memory)
COM Port	Select the COM port for the USB Cable or Bluetooth. USB cable driver must be installed in order the Serial to TTL connection to operate.

Live IO-View		
Parameter Name	Description	Range
<b>INPUTS</b>		
Internal Sensor	Internal Temperature Sensor Reading	0..50°C (32..122°F)
External Sensor 1	External Temperature Sensor 1 Reading (RI1)	0..50°C (32..122°F)
External Sensor 2	External Temperature Sensor 2 Reading (RI2, with -RI2 option)	0..50°C (32..122°F)
0-10V Input 1	Analogue Input 1; 0-10V (AI1 Option)	0..100%
0-10V Input 2	Analogue Input 2; 0-10V (AI2 Option)	0..100%
Humidity Sensor	Relative Humidity Measurement	0..100%
LUX Sensor	LUX Sensor Reading	0..3,000 LUX
Setpoint Adjust	Current Setpoint Adjustment	-20..+20°C/°F
Occupancy	Occupancy Status	Off - On
Digital Input 1	Digital Input 1 Status	Off - On
Digital Input 2	Digital Input 2 Status	Off - On
Configuration Switch	Bit Switch Position	00000000-11111111
<b>OUTPUTS</b>		
Triac 1	Digital Output 1	Off - On
Triac 2	Digital Output 2	Off - On
Analogue Output 1	Analogue Output 1	0..100%
Analogue Output 2	Analogue Output 2	0..100%
Analogue Output 3	Analogue Output 3	0..100%
Analogue Output 4	Analogue Output 4	0..100%
Thermic1 Position	Thermic Output 1 Position	0..100%

<b>Live IO-View</b>		
<b>Parameter Name</b>	<b>Description</b>	<b>Range</b>
Thermic2 Position	Thermic Output 2 Position	0..100%
Three Point Position	Three Point Output Position	0..100%
<b>CONTROL</b>		
Calculated Setpoint	Calculated Temperature Control Setpoint	12..86°C/°F
Heating Demand	Heating Control Loop Output	0..100%
Cooling Demand	Cooling Control Loop Output	0..100%
CO2 Demand	CO2 Control Loop Output	0..100%
Humidification Demand	%RH Control Loop Humidification Output	0..100%
De-Humidification Demand	%RH Control Loop De-Humidification Output	0..100%
Fan Speed Demand	Fan Control Loop Output	0..100% or 0-1-2-3
Aux Loop Demand	Auxiliary Control Loop Output	0..100%
Override State	Controller Operating Mode Status	0 = None / Day 1 = Night

<b>Control Parameters</b>		
<b>Parameter Name</b>	<b>Description</b>	<b>Range</b>
Setpoint	Setpoint Middle Position.	12..86°C/°F (Default 21.0°C)
Setpoint Adjust Max	Temperature Setpoint Maximum Adjustment	0.0...20°C/°F (Default 3.0)
Setpoint Adjust Min	Temperature Setpoint Minimum Adjustment	-20.0...0°C/°F (Default -3.0)
Setpoint Adjustment Save	Saves the user Setpoint Adjustment Automatically to Flash (applicable only for SPB option)	0 = Do Not Save (Default) 1 = Save Setpoint Adjustment
Setpoint Adjustment Reset	Resets the User Setpoint Adjustment on Night to Day Transition via Bus (applicable only for SPB option)	0 = Retain Current SPA (Default) 1 = Reset Setpoint Adjustment
Proportional Band	Proportional Ban	1.0..50.0 °C/°F (Default 4.0)
Integral Action Time	Integral Action time of the control loop. Set to 0 to disable.	0..1,200 seconds (Default 600s)
Deadzone	Deadzone Between Heating and Cooling Stages in Day Mode	0.0..6.0°C/°F (Default 1.5°C)
Heating Stages	Number of Heating Stages	0 = None 1 = 1-Stage (Default) 2 = 2-Stages
Heating Stage 1 Direction	Heating Stage 1 Direction	0 = Reverse (Default) 1 = Direct
Heating Stage 2 Direction	Heating Stage 2 Direction	0 = Reverse (Default) 1 = Direct
Cooling Stages	Number of Cooling Stages	0 = None 1 = 1-Stage (Default) 2 = 2-Stages
Cooling Stage 1 Direction	Cooling Stage 1 Direction	0 = Reverse 1 = Direct (Default)
Cooling Stage 2 Direction	Cooling Stage 2 Direction	0 = Reverse 1 = Direct (Default)
Night Mode	Night Control Mode	0 = Expanded Deadzone (Default) 1 = Night OFF Mode
Night Deadzone	Deadzone Between Heating and Cooling Stages in Night Mode (Expanded Deadzone Mode)	0.0..40.0°C/°F (Default 6.0°C)
Night Frost Setpoint	Night Frost Setpoint (Night OFF Mode)	0.0...71.0°C/°F (Default 8.0°C)
<b>CO2 CONTROL</b>		
CO2 Control Setpoint	CO2 Setpoint	0..5000ppm (Default 1,000 ppm)
CO2 Proportional Band	CO2 Proportional Band	10..5000 ppm (Default = 300 ppm)
CO2 Control Integral Action	Integral Action time of the CO2 control loop. Set to 0 to disable.	0..10,000 seconds (Default 0)
Output Direction	Direction of the CO2 control actuator.	0 = Reverse Acting 1 = Direct Acting (Default)
<b>HUMIDITY</b>		
Humidity Control Setpoint	Humidity Setpoint	0.0...100.0 %rH (Default 50%)
Humidity Proportional Band	Humidity Proportional Band	0.1...100.0 %rH (Default 20.0%)

<b>Control Parameters</b>		
<b>Parameter Name</b>	<b>Description</b>	<b>Range</b>
Humidity Control Integral Action	Integral Action time of the humidity control loop. Set to 0 to disable.	0..10,000 seconds (Default 0)
Humidification Output Direction	Direction of the humidification output (actuator direction, Direct = 0..100%, Reverse = 100..0%).	0 = Reverse Acting 1 = Direct Acting (Default)
De-Humidification Output Direction	Direction of the dehumidification output (actuator direction, Direct = 0..100%, Reverse = 100..0%).	0 = Reverse Acting 1 = Direct Acting (Default)
<b>FAN SPEED CONTROL</b>		
Fan Speed Mode Selection	Selecting the Fan Speed Mode	0 = 0..100% Modulating 1 = 0 - 1 2 = 0 - 1 - 2 (default) 3 = 0 - 1 - 2 - 3 4 = None
Fan Speed By	Fan Speed Control Source	0 = Heating 1 and Cooling 1 Stage (Default) 1 = Heating Stage1 2 = Cooling Stage 1 3 = Heating and Cooling Stage 2 4 = Heating Stage 2 5 = Cooling Stage 2 6 = CO2 7 = Humidification 8 = De-humidification 9 = Auxiliary Loop 10 = Push Button Boost
Min Active Level	Fan Speed Minimum Active Level	0...100 %rH (Default 20%)
<b>AUXILIARY CONTROL LOOP</b>		
Aux Control Setpoint	Aux Loop Setpoint	12..86°C/°F (Default 21.0°C)
Aux Proportional Band	Aux Loop Proportional Band	1.0..50.0 °C/°F (Default 4.0)
Aux Control Integral Action	Integral Action time of the Aux control loop. Set to 0 to disable.	0..1,200 seconds (Default 600s)
Output Direction	Direction of the CO2 control actuator.	0 = Reverse Acting (Default) 1 = Direct Acting
Enable Aux Loop	Enables Auxiliary Control Loop (Activates RI1)	0 = Disabled (Default) 1 = Enabled

<b>Inputs / Outputs</b>		
<b>Parameter Name</b>	<b>Description</b>	<b>Range</b>
<b>INPUTS</b>		
Internal Sensor Offset	One Point Internal Temperature Calibration Field	-10.0..+10.0°C/°K (Default 0°C)
External Sensor Offset	One Point External Temperature Calibration Field	-10.0..+10.0°C/°K (Default 0°C)
CO2 Sensor Offset	CO2 Sensor Calibration	-500...+500 ppm
Humidity Sensor Offset	Humidity Sensor Calibration	-5...+5%rH
DI1 Function	Digital Input 1 Function	0 = Override Day (PIR Mode) - Default 1 = Override Night (Windows Switch Mode) 2 = Disable Cooling (Condensation Switch Mode) 3 = None 4 = Boost Heating Stage 1 5 = Boost Cooling Stage 1 6 = Boost Fan Loop 7 = Boost CO2 Loop
DI1 Delay	Delay Time Setting for Digital Input 1	0..28800 Seconds (Default 0s)

Inputs / Outputs		
Parameter Name	Description	Range
DI2 Function	Digital Input 2 Function	0 = Override Day (PIR Mode) - Default 1 = Override Night (Windows Switch Mode) 2 = Disable Cooling (Condensation Switch Mode) 3 = None 4 = Boost Heating Stage 1 5 = Boost Cooling Stage 1 6 = Boost Fan Loop 7 = Boost CO2 Loop
DI2 Delay	Delay Time Setting for Digital Input 2	0..7200 Seconds (Default 0s)
Push Button Boost	Push Button Boost Target	0 = Heating Stage 1 (Default) 1 = Heating Stage 1&2 2 = Cooling Stage 1 3 = Cooling Stage 1&2 4 = Fan Control Loop 5 = CO2 Control Loop 6 = Humidification 7 = De-humidification 8 = Maximum VAV 9 = Output
Push Button Off Delay	Delay Time Setting for Push Button	1..28800 Seconds (Default 600s)
Push Button Mode	Sets the Operation Mode of the Push Button.	0 = 0% (Overrides to 0%) 1 = 100% (Overrides to 100%, Default) 3 = Stepped (Rotates 0%-25%-50%-75%-100%-Cancel)
Push Button Steps	Sets the number of steps when "Stepped Mode" is used with the Push Button.	0..5
Occupancy Sensor Mode	Selects if the occupancy sensor is used for control or for monitoring only.	0 = Display Only (Default) 1 = Day/Night Control 2 = Boost Heating Stage 1 3 = Boost Cooling Stage 1 4 = Boost Fan Loop 5 = Boost CO2 Loop
Occupancy Off Delay	Delay Time Setting for Occupancy	1..28800 Seconds (Default 600s)
<b>OUTPUT ASSIGNMENTS</b>		
AO1 (Y1)	Analogue Output Y1 Mode	0 = Network Value 1 = None 2 = Heating Stage 1 (Default) 3 = Heating Stage 2 4 = Cooling Stage 1 5 = Cooling Stage 2 6 = Air-Side 7 = Modulating Fan (EC or Step) 8 = CO2 Control 9 = Maximum VAV 10 = Maximum Fan 11 = Humidification 12 = De-humidification 13 = Aux Control Loop 14 = 3-Point Open 15 = 3-Point Close 16 = Push Button

Inputs / Outputs		
Parameter Name	Description	Range
AO2 (Y2)	Analogue Output Y2 Mode	0 = Network Value 1 = None 2 = Heating Stage 1 3 = Heating Stage 2 4 = Cooling Stage 1 (Default) 5 = Cooling Stage 2 6 = Air-Side 7 = Modulating Fan (EC or Step) 8 = CO2 Control 9 = Maximum VAV 10 = Maximum Fan 11 = Humidification 12 = De-humidification 13 = Aux Control Loop 14 = 3-Point Open 15 = 3-Point Close 16 = Push Button
AO3 (Y3)	Analogue Output Y3 Mode	0 = Network Value 1 = None 2 = Heating Stage 1 3 = Heating Stage 2 4 = Cooling Stage 1 5 = Cooling Stage 2 (Default) 6 = Air-Side 7 = Modulating Fan (EC or Step) 8 = CO2 Control 9 = Maximum VAV 10 = Maximum Fan 11 = Humidification 12 = De-humidification 13 = Aux Control Loop 14 = 3-Point Open 15 = 3-Point Close 16 = Push Button
AO4 (Y4)	Analogue Output Y4 Mode	0 = Network Value 1 = None 2 = Heating Stage 1 3 = Heating Stage 2 4 = Cooling Stage 1 5 = Cooling Stage 2 6 = Air-Side 7 = Modulating Fan (EC or Step) (Default) 8 = CO2 Control 9 = Maximum VAV 10 = Maximum Fan 11 = Humidification 12 = De-humidification 13 = Aux Control Loop 14 = 3-Point Open 15 = 3-Point Close 16 = Push Button
AO1 (Y1) Minimum Output	Analogue Output Y1 Minimum Value	0..100%(0% = default)
AO1 (Y1) Maximum Output	Analogue Output Y1 Minimum Value	0..100% (100% = default)
AO2 (Y2) Minimum Output	Analogue Output Y2 Minimum Value	0..100%(0% = default)
AO2 (Y2) Maximum Output	Analogue Output Y2 Minimum Value	0..100% (100% = default)
AO3 (Y3) Minimum Output	Analogue Output Y3 Minimum Value	0..100%(0% = default)
AO3 (Y3) Maximum Output	Analogue Output Y3 Minimum Value	0..100% (100% = default)
AO4 (Y4) Minimum Output	Analogue Output Y4 Minimum Value	0..100%(0% = default)
AO4 (Y4) Maximum Output	Analogue Output Y4 Minimum Value	0..100% (100% = default)



Inputs / Outputs		
Parameter Name	Description	Range
Thermic/On-Off 1	Thermic/On-Off Output 1 Mode (Linked to DO1)	0 = Network Value 1 = None 2 = Heating Stage 1 (Default) 3 = Heating Stage 2 4 = Cooling Stage 1 5 = Cooling Stage 2 6 = Air-Side 7 = Modulating Fan (EC or Step) 8 = CO2 Control 9 = Maximum VAV 10 = Maximum Fan 11 = Humidification 12 = De-humidification 13 = Aux Control Loop 14= Push Button
Thermic/On-Off 2	Thermic/On-Off Output 2 Mode (Linked to DO2)	0 = Network Value 1 = None 2 = Heating Stage 1 3 = Heating Stage 2 4 = Cooling Stage 1 (Default) 5 = Cooling Stage 2 6 = Air-Side 7 = Modulating Fan (EC or Step) 8 = CO2 Control 9 = Maximum VAV 10 = Maximum Fan 11 = Humidification 12 = De-humidification 13 = Aux Control Loop 14= Push Button
3-Point	Three Point Output Mode (Linked to DO1 & DO2) NOTE: If selected Thermic 1 and Thermic 2 are automatically set to None.	0 = Network Value 1 = None (Default) 2 = Heating Stage 1 3 = Heating Stage 2 4 = Cooling Stage 1 5 = Cooling Stage 2 6 = Air-Side 7 = CO2 Control 8 = Maximum VAV 9 = Maximum Fan 11 = Humidification 12 = De-humidification 13 = Aux Control Loop 14= Push Button
DO1	Digital Output 1 Mode. Set to Control to activate PWM or On/Off control logic.	0 = Network 1 = Fan Speed 1 2 = Fan Speed 2 3 = Thermic 1 4 = Thermic 2 5 = 3-Point Open 6 = 3-Point Close
DO2	Digital Output 2 Mode. Set to Control to activate PWM or On/Off control logic.	0 = Network 1 = Fan Speed 1 2 = Fan Speed 2 3 = Thermic 1 4 = Thermic 2 5 = 3-Point Open 6 = 3-Point Close
<b>THERMIC ACTUATORS</b>		
Mode	Thermic Actuator Mode	0 = PWM (Pulse Width Modulation, Default) 1 = On/Off
Min. Level	Minimum Output Level (Switch Off Level)	0..100% (Default 0)
Max. Level	Maximum Output Level (Switch On Output)	10..100% (Default 100)
PWM Period	Pulse Width Modulation Period	0..255 seconds (Default 30)
<b>3-POINT ACTUATOR</b>		
Stroke Time	3-Point Actuator Running Time	30..600 seconds (Default 150)
Run On Time	3-Point Actuator Run On Time when Fully Open /Closed	0..30 seconds (Default 6)

Inputs / Outputs		
Parameter Name	Description	Range
Output Mode	Sets the 3-Point Output model. Linear = Standard 3-Point. Stepped = Follows the number of steps set in the Push Button Steps parameter.	0 = Linear (Default) 1 = Stepped
<b>VALVE EXERCISE (AntiJAM)</b>		
Anti-Jam Timeout	Valve Exercise Monitoring Period.	0 = Disabled (Default) 1-14 days

Alarm/Display/Comms		
Parameter Name	Description	Range
<b>DISPLAY</b>		
Temperature Units	Temperature Unit Selection	0 = Celsius (Default) 1 = Fahrenheit
LCD brightness	Brightness of the LCD white backlight.	Off - 10% to 100% (Default Off)
Info Line	Info Line Configuration	0 = Show Valve Position 0-100% (default) 1 = Show Fan Speed 2 = None
Alternating Display Options	Alternating CO2 and RH Display	0 = Disabled (Default) 1 = Alternate CO2 Only 2 = Alternate RH Only 3 = Alternate CO2 and RH
<b>COMMS</b>		
BACnet Baud Rate NOTE: Does not show Modbus Baud Rate set via bit switches.	BACnet Baud Rate (can only be set if BR1 and BR2 are in OFF position)	0 = 9600 (Default) 1 = 19200 2 = 38400 3 = 76800
Stop Bits	Stop Bits	0 = 1 Stop Bit (Default) 1 = 2 Stop Bits
Address NOTE: Does not show BACnet address set via bit switches.	BACnet Address (can only be set if all address bit switches are in OFF position)	0..247 (Default 1)
<b>ALARMS</b>		
Alarm 1 Source	Source for the Alarm Display	0 = CO2 Sensor 1 = Temperature 2 = Humidity 3 = None (Default)
Alarm 1 Amber Threshold	Alarm 1 Amber Backlight Switching Point	0..5000 (Default 0)
Alarm 1 Red Threshold	Alarm 1 Amber Backlight Switching Point	0..5000 (Default 0)
Alarm 1 Hysteresis	Hysteresis for Alarm 1	0..5000 (Default 0)
Alarm 2 Source	Source for the Alarm Display	0 = CO2 Sensor 1 = Temperature 2 = Humidity 3 = None (Default)
Alarm 2 Amber Threshold	Alarm 2 Amber Backlight Switching Point	0..5000 (Default 0)
Alarm 2 Red Threshold	Alarm 2 Amber Backlight Switching Point	0..5000 (Default 0)
Alarm 2 Hysteresis	Hysteresis for Alarm 2	0..5000 (Default 0)
Alarm 3 Source	Source for the Alarm Display	0 = CO2 Sensor 1 = Temperature 2 = Humidity 3 = None (Default)
Alarm 3 Amber Threshold	Alarm 3 Amber Backlight Switching Point	0..5000 (Default 0)
Alarm 3 Red Threshold	Alarm 3 Amber Backlight Switching Point	0..5000 (Default 0)
Alarm 3 Hysteresis	Hysteresis for Alarm 3	0..5000 (Default 0)

**Parameter Storage**

The configuration parameters are stored in the non-volatile memory. When the changes are carried out via the Configuration Tool, the parameters are stored in the non-volatile memory when the controller returns to a normal display mode. If the changes are carried out over the network (Modbus), then "NonVol Update" flag is required to be forced on to save the changes.

**Setting Up BACnet Address and Baud Rate**

The SRC BACnet address and the baud rate is normally set through the bit switch. It is also possible to set the address and baud rate over the BACnet communication network.

**NOTE: The new settings are activated automatically after approx 5 seconds if the bit switch positions have not been moved. In this case the controller reset is applied to activate the new settings. .**

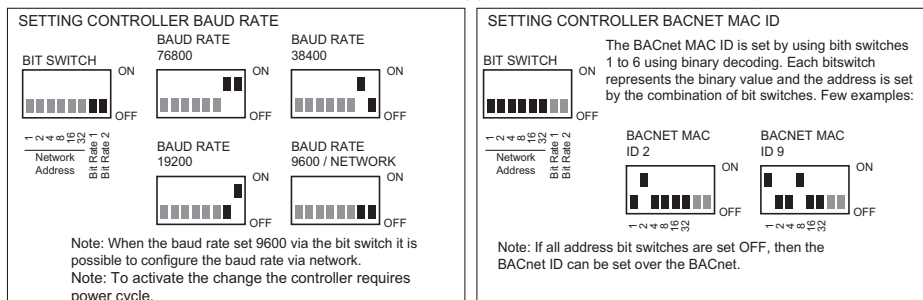

**BACnet Standard Object Types Supported**

No dynamic Creation or Deletion supported. Objects, and object instances, are assigned to fixed functions within the proprietary control application of the product as follows:

Object	Number Of Instances	Instance Assignments
Device Object	1	
Analog Input	5	AI(0) – Built-In Temperature Sensor AI(1) – External Temp Sensor / AI1 AI(2) – Calculated Setpoint AI(3) - CO2 Sensor AI(4) - Humidity Sensor AI(5) - LUX Sensor AI(6) - Resistive Input 2 / AI2
Analog Outputs	7	AO(0) – Y1 Output AO(1) – Y2 Output AO(2) – Y3 Output AO(3) - Y4 Output AO(4) - Thermic1_Position AO(5) - Thermic2_Position AO(6) - ThreePoint_Position
Analogue Value	13	AV(0) – Temperature Setpoint AV(1) – CO2 Setpoint AV(2) – Humidity Setpoint AV(3) – LCD Brightness AV(4) – Y1 Minimum AV(5) – Y1 Maximum AV(6) – Y2 Minimum AV(7) – Y2 Maximum AV(8) – Y3 Minimum AV(9) – Y3 Maximum AV(10) – Y4 Minimum AV(11) – Y4 Maximum AV(12) – Aux Setpoint
Binary Input	2	BI(0) – Override Input (DI1) BI(1) – Override Input (DI2) BI(2) – Occupancy (PIR)
Binary Output	4	BO(0) – DO1 Output Status BO(1) – DO2 Output Status BO(2) = Night Mode Override BO(3) = Setpoint Reset
MutiState Input	3	MSI(0) - Alarm 1 Level MSI(1) - Alarm 2 Level MSI(3) - Alarm 3 Level

**Device Object Properties (Required Object Properties)**

Property Name /ID	Attributes	Range	Default
Object Identifier	R/W		MAC_Address + 651000
Object Name	R/W	32 Characters Max	Concatenation of product type and MAC address i.e. "SRC_001"
Object Type	R		8
System Status	R		STATUS_OPERATIONAL

Property Name /ID	Attributes	Range	Default
Vendor Name	R		SyxthSense
Vendor Identifier			651
Model Name	R		URD
Protocol Version	R		1
Protocol Revision	R		10
Max APDU Length	R		480
Segmentation Support	R		No
APDU Timeout	R		3000 ms
Number APDU Retries	R		3
MaxMaster	R		127
Max_Info_Frames	R		1
Database Revision	R		0

### Analogue Input Objects

	Property Name /ID	Attributes	Range	Default
<b>Required Object Properties</b>	Object Identifier	R		
	Object Name	R		AI(0) – Built-In Temperature Sensor AI(1) – External Temperature Sensor / AI1 (with AI1 option) AI(2) – Calculated Setpoint AI(3) - CO2 Sensor AI(4) - Humidity Sensor AI(5) - LUX Sensor AI(6) - Resistive Input 2 (RI2 option) / AI2 (AI2 option)
	Object Type	R		0
	Present Value	R/W	AI(0): 0..150 AI(1): 0..150 AI(2): 0..150 AI(3): 0..5,000 AI(4): 0..100 AI(5): 0..3000 AI(6): 0..150	
	Status Flag	R		
	Event State	R		
	Out-Of-Service	R/W		FALSE
	Units	R		AI(0): UNITS_DEGREES_CELCIUS or UNITS_DEGREES_FAHRENHEIT AI(1): UNITS_DEGREES_CELCIUS or UNITS_DEGREES_FAHRENHEIT AI(2): UNITS_DEGREES_CELCIUS or UNITS_DEGREES_FAHRENHEIT AI(3): UNITS_PARTS_PER_MILLION AI(4): UNITS_PERCENT AI(5): NO_UNITS AI(6): UNITS_DEGREES_CELCIUS or UNITS_DEGREES_FAHRENHEIT
<b>Optional Properties</b>	None			
<b>Proprietary Properties</b>	None			

## Analogue Output Objects

	Property Name /ID	Attributes	Range	Default
<b>Required Object Properties</b>	Object Identifier	R		
	Object Name	R		AO(0) = "Y1" AO(1) = "Y2" AO(2) = "Y3" AO(3) = "Y4" AO(4) = "Thermic1_Position" AO(5) = "Thermic2_Position" AO(6) = "ThreePoint_Position"
	Object Type	R		1
	Present Value	R/W	0..100	
	Status Flag	R		
	Event State	R		
	Out-Of-Service	R/W		FALSE
	Units	R		UNITS_PRECENT
<b>Optional Properties</b>	None			
<b>Proprietary Properties</b>	None			

## Analogue Value Objects

	Property Name /ID	Attributes	Range	Default
<b>Required Object Properties</b>	Object Identifier	R		
	Object Name	R		AV(0) – Temperature Setpoint AV(1) – CO2 Setpoint AV(2) – Humidity Setpoint AV(3) – LCD Brightness AV(4) – Y1 Minimum AV(5) – Y1 Maximum AV(6) – Y2 Minimum AV(7) – Y2 Maximum AV(8) – Y3 Minimum AV(9) – Y3 Maximum AV(10) – Y4 Minimum AV(11) – Y4 Maximum AV(12) – Aux Setpoint
	Object Type	R		2
	Present Value	R/W	AV(0): 12..86 AV(1): 0..5000 AV(2): 0..100.0 AV(3): 0..10 AV(4,11): 0..100.0	
	Status Flag	R		
	Event State	R		
	Out-Of-Service	R/W		FALSE
	Units	R		AV(0,12) = UNITS_DEGREES_CELSIUS or UNITS_DEGREES_FAHRENHEIT AV(1): UNITS_PARTS_PER_MILLION AV(2): UNITS_PRECENT AV(3) = NO_UNITS AV(4,11): UNITS_PRECENT
	Priority Array	R		
	Relinquish Default	R/W		AV(0,12) = Nonvol Temperature Setpoint AV(1) = Nonvol CO2 Setpoint AV(2) = Nonvol Humidity Setpoint AV(3) = Nonvol LCD Brightness AV(4,11) = Nonvol Min/Max Values
	<b>Optional Properties</b>	None		

	Property Name /ID	Attributes	Range	Default
<b>Proprietary Properties</b>	None			

**Binary Input Objects**

	Property Name /ID	Attributes	Range	Default
<b>Required Object Properties</b>	Object Identifier	R		
	Object Name	R		BI(0) = "DI1" BI(1) = "DI2" BI(2) = "Occupancy"
	Object Type	R		3
	Present Value	R/W	0..1	
	Status Flags	R		
	Event State	R		
	Out-Of-Service	R/W		FALSE
	Polarity	R/W		POLARITY_NORMAL
	Active Text	R		"on"
	Inactive Text	R		"off"
<b>Optional Properties</b>	None			
<b>Proprietary Properties</b>	None			

**Binary Output Objects**

	Property Name /ID	Attributes	Range	Default
<b>Required Object Properties</b>	Object Identifier	R		
	Object Name	R		BO(0) = "DO1" BO(1) = "DO2" BO(3) = "Night_Mode_Override" BO(4) = "SPA Reset"
	Object Type	R		4
	Present Value	R/W	0..1	
	Status Flags	R		
	Event State	R		
	Out-Of-Service	R/W		FALSE
	Polarity	R/W		POLARITY_NORMAL
	Priority Array	R		
	Relinquish Default	R/W		BINARY_INACTIVE
	Active Text	R		"on"
	Inactive Text	R		"off"
<b>Optional Properties</b>	None			
<b>Proprietary Properties</b>	None			

**Multi-State Input Objects**

	Property Name /ID	Attributes	Range	Default
<b>Required Object Properties</b>	Object Identifier	R		
	Object Name	R		MSI(0) = "Alarm 1 Level" MSI(1) = "Alarm 2 Level" MSI(2) = "Alarm 3 Level"
	Object Type	R		13
	Present Value	R/W	1,2,3 (Green, Amber, Red)	
	Status Flags	R		
	Event State	R		
	Out-Of-Service	R/W		FALSE
	Number-Of-States	R		3
<b>Optional Properties</b>	None			
<b>Proprietary Properties</b>	None			

**Dimensions**

