

Smart controller M30 with high resolution touch screen to control and monitor up to 30 motorized fire or smoke extraction dampers and 15 smoke detectors via BACnet.



Content

Section (continuation)	Page	Section (continuation)	Page
Technical Data	1	Functionality Dip Switches	8
Cable Specification	3	Remote Access through Cloud	9
Functionalities / Dimensions	5	Bus Monitoring Functionality	9
Electrical Installation	6	User Manual	9
Explanation Application	7		

Technical Data

Electrical Data	Operating Voltage	5 V DC (Power supply for 230 V AC included in delivery)
	Power Consumption	< 10 W
	Electric Current	3 A
	Connections	Quick connection terminals

Communication / BACnet



Functionality	For 1 zone with max. 15 BACnet devices (FSC-UFC24, FSC-UFC24-2, FSC-UFC230-2, FSC-UFC24-NM-4, FSC-UFC24-230). Takes over the controls function for the participants of the zone
Protocol	BACnet MS/TP
Medium	RS-485, not electrically isolated
Number of Devices per Line	Max. 15 BACnet devices (FSC-UFC24, FSC-UFC24-2, FSC-UFC230-2, FSC-UFC24-NM-4, FSC-UFC24-230) without repeater. One line with max. 15 devices available

	Baud Rates	Auto detect. 9.600, 19.200, 38.400, 76.800 bps. Default 38.400 bps
	Device Instant Adresses Termination	Zone 1: 804121 FSC-UFC... addresses from 1-15 120Ω line termination. Jumper available on extra pin on PCB. Position of jumper if FSC-M30 is last BACnet device in line, see page 6
	Typical Response Time	< 100 ms
Safety	Protection Class	III
	Protection Degree	IP42, housing of non-flammable polycarbonate
	EMC Correlation Emission	EN61000-6-3 and EN55022
	EMC Correlation Immunity	EN50130-4 and EN55024
	Electrical Safety	EN60950-1
	Ambient Temperature	10° C to +30° C
	Storage Temperature	0° C to +40° C
	Maintenance	Maintenance free
Mechanical Data (Dimensions / Weight)	Width	135 mm
	Height	75 mm
	Length	185 mm
	Weight	approx. 1 kg
	See drawing page 5.	
Installation	Mounted on DIN Rail, mounting bracket or screw fixed.	

Electrical Installation See details page 6.

Safety Notes The FSC-M30 is not allowed to be used outside the specified field of application, especially in aircraft or in any other airborne means of transport. The company buying and / or mounting the FSC-M30 on site bears full responsibility for the proper functioning of the whole system. Only authorized specialists may carry out the installation. All applicable legal or institutional installation regulations must be complied with during installation. The device contains electrical and electronic components and is not allowed to be disposed of as domestic refuse. All locally valid regulations and requirements must be observed.

Product Features / Application The FSC-M30 is a smart controller with a high resolution touch screen to control and monitor up to 30 motorized fire or smoke extraction dampers, 15 smoke detectors as well as 15 thermoelectric tripping devices. One zone can be built with the FSC-M30: Either one fire or one smoke extraction zone. It is mounted in the cabinet or according to customer's need. Integrated real time clock and intuitive handling. Internet access via WiFi. Cloud access available. Fully autonomous operation (Stand Alone Application). Control of 1 ventilator (input/output), 1 alarm input (external alarm), 1 alarm output (internal alarm) and other inputs/outputs are integrated.

Power Supply The FSC-M30 needs to be powered up with 5 V DC (Power supply for 230 V AC included in delivery).

Cable Specification



For the connection of the FSC-M30 with the FSC-UFC... devices the following cable specifications apply:
120Ω with 1 Mhz. Made of 24 # flexible twisted pairs overall foil + braidshielded and overall jacketed with a flexible compound for indoor use, or similar. Cable type: Belden 3105a or equivalent.

IMPORTANT: SMT takes no responsibility of the functionality of the units/network if a different cable is used to the one specified here.

Communication BACnet MS/TP (RS-485) to the connected UFC devices.
Remote control via WiFi possible.
Cloud access available.

Connection Field Devices Up to 15 pcs. FSC-UFC24, FSC-UFC24-2, FSC-UFC230-2, FSC-UFC24-NM-4, FSC-UFC24-230 can be connected to the FSC-M30. The FSC-M30 automatically recognizes the connected FSC-UFC... (automatic recognition of the addresses, subject to correct addressing through the dip switches). The addressing of the FSC-UFC... is recommended to be in consecutive order.

Additional Connections *Input and Output Modules*
I/O connections: 3 x DO, 3 x DI
Input for Fire Alarm System is included in the 3 DI.



IMPORTANT NOTICE

Please be aware, that the FSC-M30 gives NO signal for the fan to be shut off when testing only single dampers. Depending on where the damper is located, a manual shut down of the fans has to be considered when testing a single damper (e.g. the one which is closest to the fan). This is in the responsibility of the person / company doing the tests. SMT AG will not take any liability in any such case.



PROPER HANDLING

The screen is connected to the body by 1 cable. Do not disassemble the cable. When the screen unit needs to be disconnected from the I/O unit, carefully take out the plug on the PC-board mounted in the body. 1

IMPORTANT: Do not touch the electronics. Handle with care. Do not let the screen unit hanging loose only being support by the cable.

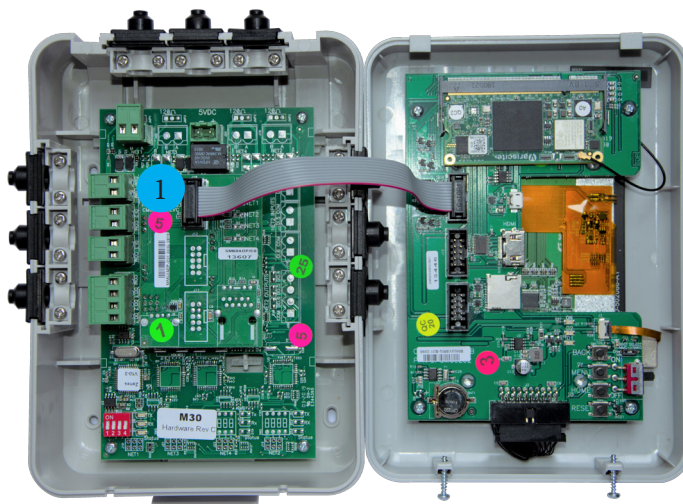

Functionalities / Dimensions

Functionalities

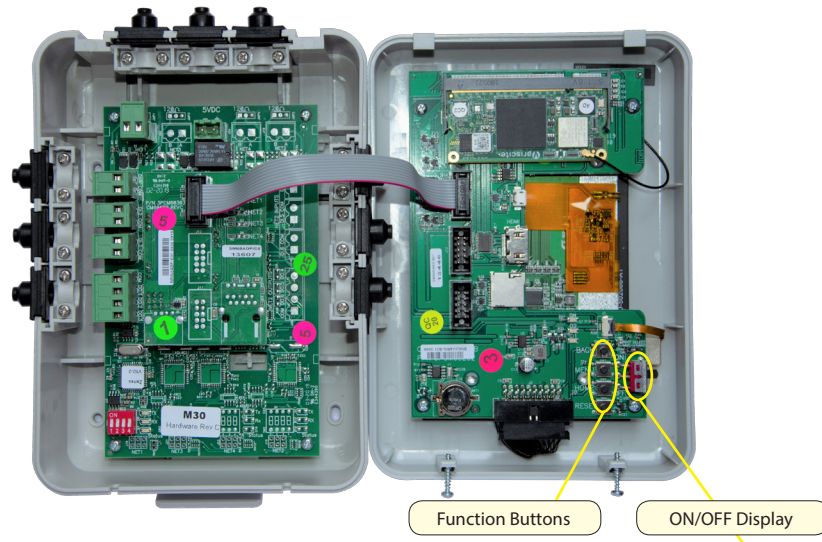

Function Buttons	For internal use only.
ON/OFF Display	The switch needs to be in ON position.

Dimensions

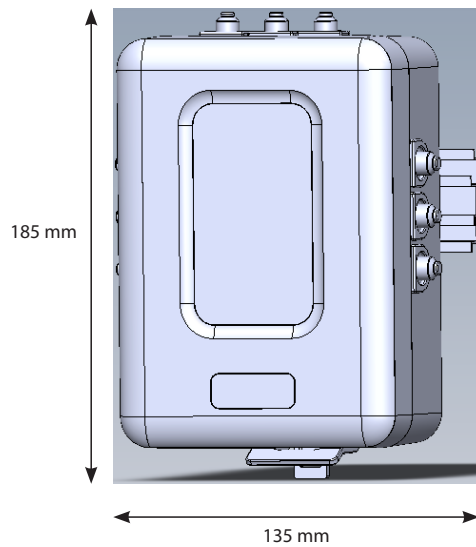

Electrical Installation

General Information

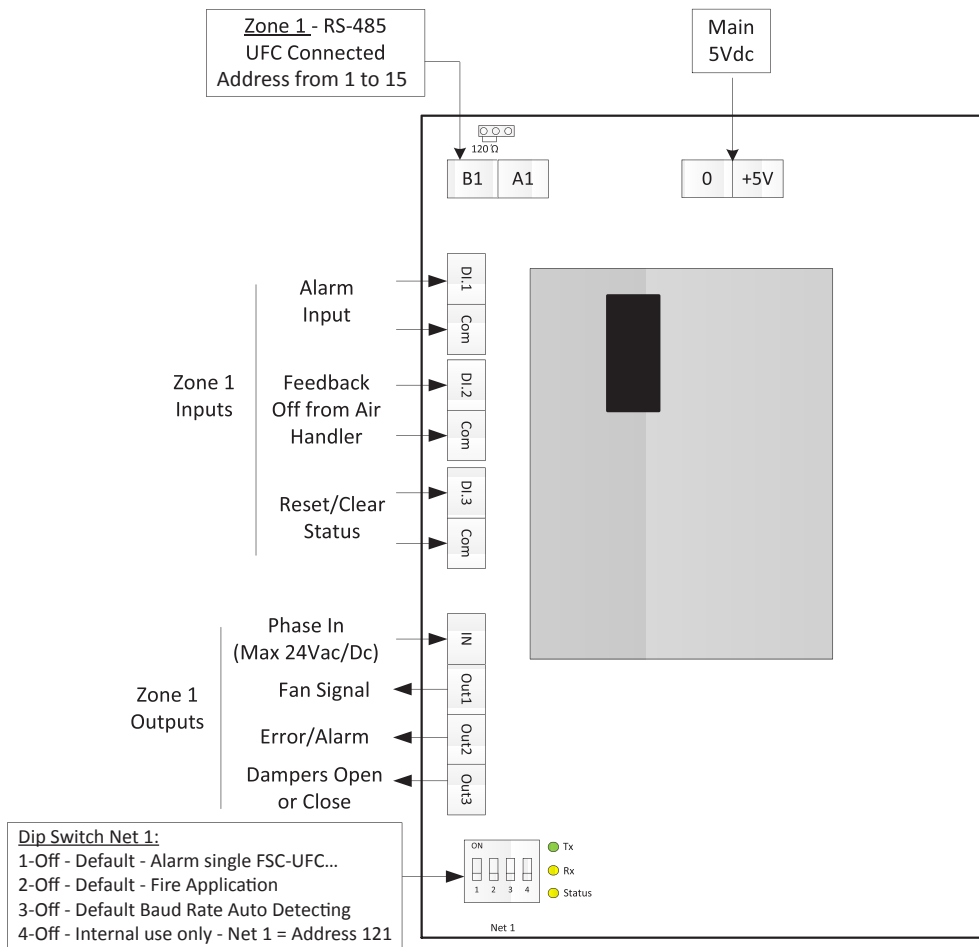

Dip Switch settings see page 8

Zone 1 – Inputs and outputs on FSC-M30 – device 121.

IMPORTANT: The fire and smoke extraction application cannot be combined within the zone! This means that the available zone can either be used as fire safety or smoke extraction zone. The control mode is set through dip switch number 2 in the UFC devices (red dip switch terminal).

Explanation Application

Fire Damper Application:

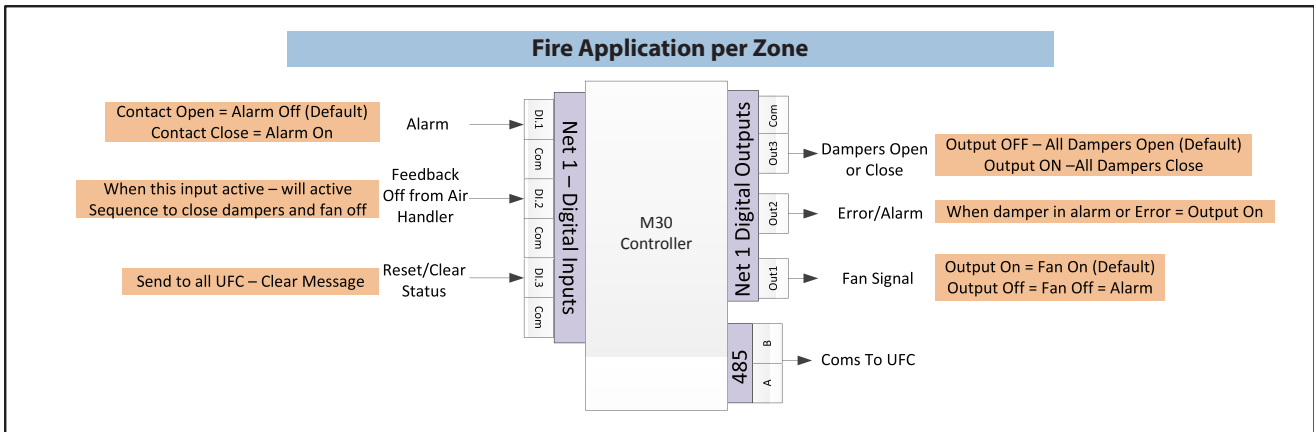

Smoke Extraction Application:

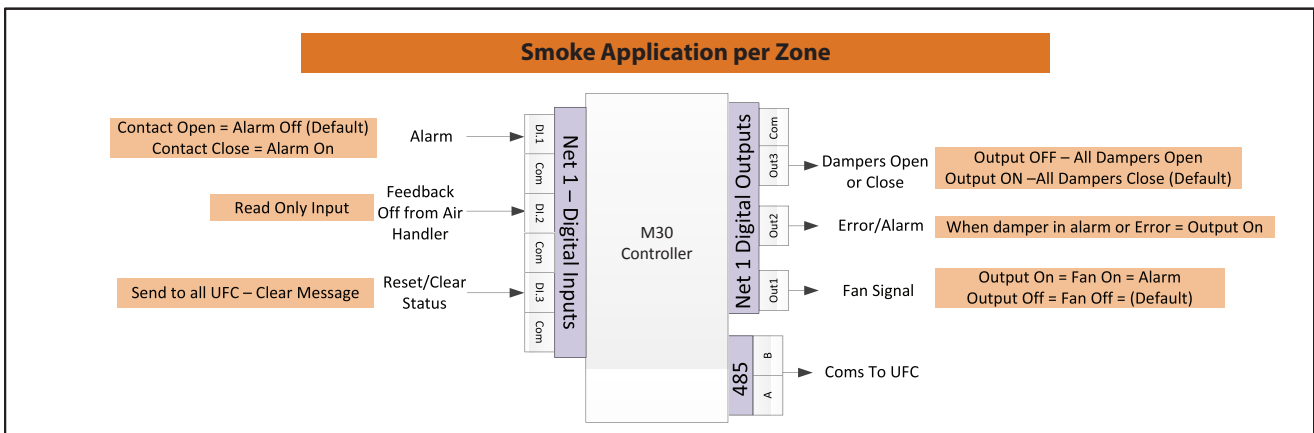

Functionality Dip Switches

Default setting Net 1 / Zone 1:

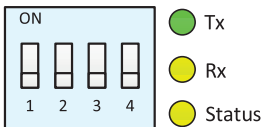

Pin	Off (Default)	On
1	Alarm in single FSC-UFC...**	Alarm all dampers in Zone 1*
2	Fire-Application	Smoke-Application
3	Auto Baudrate (only 9600)	
4	For Internal Use Only (Zone 1 = Off = Address 121)	

* Meaning: If pin 1 for zone 1 is ON and there is an alarm in this zone, all dampers will go to their safety position in zone 1.

** Meaning: If pin 1 for zone 1 is OFF and there is an alarm only the damper connected to the FSC-UFC... which detects an alarm will go to its safety position. All other dampers in this zone remain in the initial position. The alarm signal will be visible on the FSC-M30.

Remote Access through Cloud

There is the possibility to access the FSC-M30 remotely via a Cloud.

Advantages of Cloud access:

- Access to each project anytime possible without having to go there physically => complaints, service calls
- Test reports and alarm messages (alerts) can be automatically sent to registered email addresses
- For the testing of the dampers only one person is needed (confirmation during physical inspection via mobile phone => automatic logging)

Please contact us for more details.

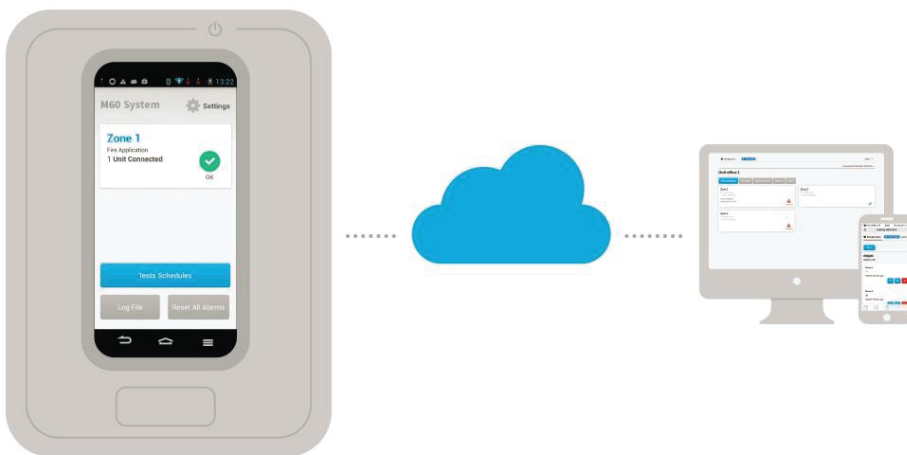

Bus Monitoring Functionality

There is the possibility to activate the bus monitoring function of the system directly in the FSC-M30. The functionality can be activated in a simple way for the whole zone or for an individual FSC-UFC... If the bus communication to a FSC-UFC..., in which the functionality is activated, is interrupted, the damper is moving to its safety position after the defined delay time.

User Manual

For more information regarding the configuration of the FSC-M30 or about the activation of the bus monitoring functionality etc. please refer to the user manual or to the data sheets of the specific FSC-UFC...